

800 SERIES

ARTICULATING BOOM LIFTS



Performance

Platform Height	80 ft	24.38 m
Horizontal Outreach		
800A	53 ft	16.15 m
800AJ	51 ft 10 in.	15.8 m
Up and Over Height	32 ft 1 in.	9.78 m
Swing	360 Degrees Continuous	
Platform, Side Entry	36 x 96 in.	0.91 x 2.44 m
Platform Capacity-Restricted		
800A only	1000 lb*	454 kg
Platform Capacity-Unrestricted	500 lb	227 kg
Platform Rotator	180 Degrees Hydraulic	
Jib Length		
800AJ	6 ft	1.83 m
Jib Range of Articulation		
800AJ	130 Degrees (+70, -60)	
Weight**	34,300 lb	15,558 kg
Max. Ground Bearing Pressure	76 psi	5.3 kg/cm ²
Drive Speed 2WD or 4WD	3.0 mph	4.8 km/h
Gradeability		
2WD	30%	
4WD	45%	
Turning Radius (Inside)		
2WS	12 ft	3.66 m
4WS	7 ft	2.13 m
Turning Radius (Outside)		
2WS	22 ft 6 in.	6.86 m
4WS	14 ft 6 in.	4.42 m

Standard Specifications

Power Source

Dual Fuel Engine		
GM Vortec 3000 MPFI	82 hp	61 kW
Diesel Engine		
Deutz TD2.9L4 Tier 4 Final	67 hp	50 kW
Fuel Tank Capacity	39 gal.	147.6 L

Hydraulic System

• Capacity	40 gal.	151.4 L
• Auxiliary Power	12V DC	

Tires

• Standard	15-625 Wide Lug Tread
• Optional	18 x 625 Foam-Filled Tires

*Except CE rating.

**Certain options or country standards will increase vehicle weight.

Standard Features

- Articulating Jib (800AJ only)
- Dual Rated Capacities (800A only)
- Oscillating Axle
- 180 Degree Hydraulic Platform Rotator
- 110V-AC Receptacle in the Platform
- 5 Degree Tilt Alarm/Indicator Light
- Swing-Out Engine Tray
- 12V-DC Auxiliary Power
- Hourmeter
- Control ADE® System
- Proportional Controls
- Gull-Wing Hoods



- Hydrostatic Drive
- Platform Console Machine Status Light Panel¹
- Lifting/Tie Down Lugs
- Engine Distress Warning
- Rim Protector Lug Tread Tires
- Engine Distress Shutdown — Selectable via Analyzer
- All Motion Alarm

1. Provides indicator lights at platform control console for system distress, 5 degree tilt light, and foot switch status.

Accessories & Options

- Platform: 36 x 72 in. (0.91 x 1.83 m)
- Operator Tool Tray
- Fall Arrest Platform, Rear Entry²: 30 x 72 in. (0.76 x 1.83 m)
- Mesh to Top Rail Bolt-on Aluminum 6 ft/8 ft
- Inward Self-Closing Swinging Gate
- Soft Touch System: 6 ft/8 ft
- 43.5 lb (19.7 kg) Propane Tank
- Cold Weather Start Kit (GM)³
- Cold Weather Start Kit (Deutz)³
- Hostile Environment Kit⁴
- Light Package⁵
- Platform Worklights
- Flashing Amber Beacon
- Arctic Package⁶
- SkyAir®
- SkyWelder®
- Pipe Rack®
- SkyGlazier®
- SkyCutter® and SkyAir® Package
- SkyWelder®/SkyCutter®/SkyAir® Combination
- SkyPower® Package — 7500 Watt Generator, power cable to platform, 1/2 in. Air Line to Platform

2. Foam-filled tires required.

3. Includes engine block heater (GM) or glow plugs (Deutz), battery heater, oil tank heater.

4. Includes console cover, boom wipers and cylinder bellows.

5. Includes head and tail lights, and platform worklights.

6. Includes arctic hydraulic hoses (drive and steer only) and main boom cable, extreme cold engine oil, fuel conditioner, engine block heater, battery blanket, glow plugs, hydraulic tank heater, and oversized footswitch. Arctic oil priced separately.

800 SERIES

ARTICULATING BOOM LIFTS



Dimensions

All dimensions are approximate.

800A

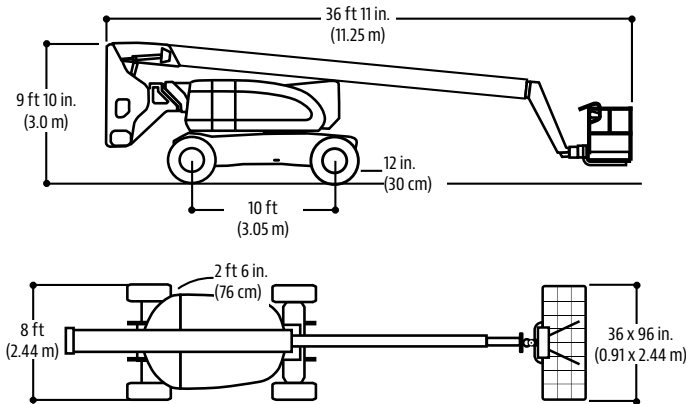

800AJ

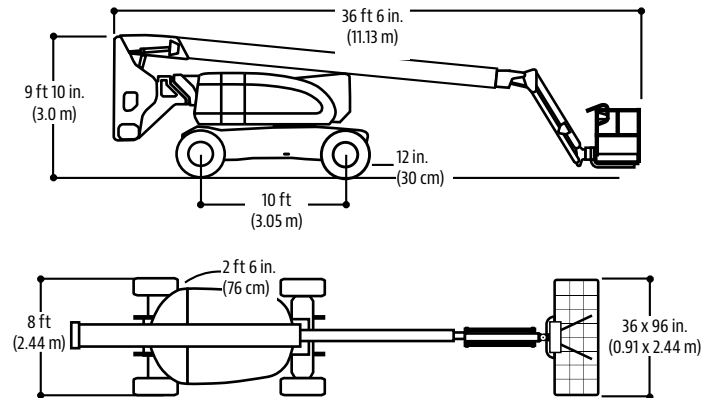

Reach Dimensions

800A

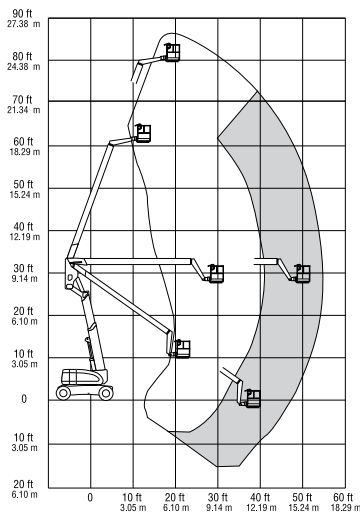

800AJ

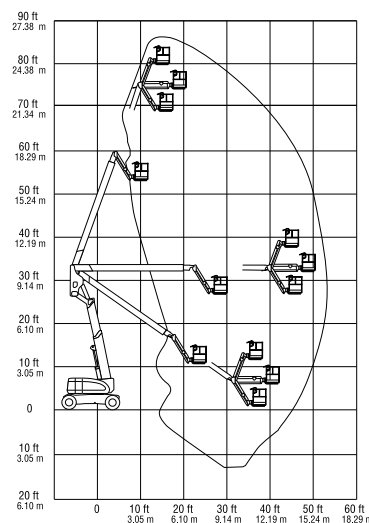

The JLG "1 & 5" Warranty

JLG Industries, Inc. backs its products with its exclusive "1 & 5" Warranty. We provide coverage on all products for one (1) full year, and cover all specified major structural components for five (5) years. Due to continuous product improvements, we reserve the right to make specification and/or equipment changes without prior notification. This machine meets or exceeds applicable OSHA Regulations in 29 CFR 1910.67, 29 CFR 1926.453, ANSI A92.5-2006, and CSA Standard CAN3-B354.2-M82, as originally manufactured for intended applications.

Part No.: 3131108
R071615
Printed in USA



JLG Industries, Inc.
 1 JLG Drive
 McCConnellsburg, PA 17233-9533
 Telephone 717-485-5161
 Toll-free in US 877-JLG-LIFT
 Fax 717-485-6417
www.jlg.com

An Oshkosh Corporation Company